

Infrared emitter IRS 3

For integration in the IR cabin

Casing: electrolytic galvanised steel plate
 Reflector: burnished aluminium reflector
 Covering grille: with protective flock spray
 Assembly: horizontal or vertical, no ceiling suspension
 Power input: 300 W
 Advantageous reaction on heat emission of ceramic material.
 Completely premounted with 3 m silicone connecting cable
 3 x 1.5 mm² and ready-made connecting plug.



Connection diagram

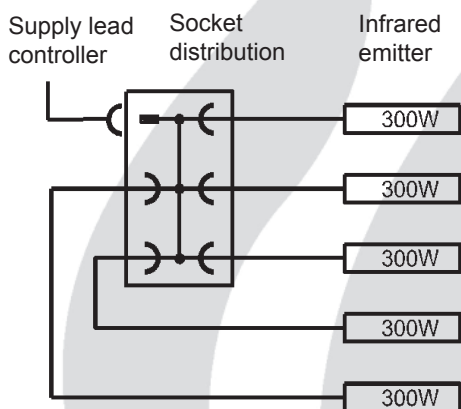

Vertical installation on cabin wall

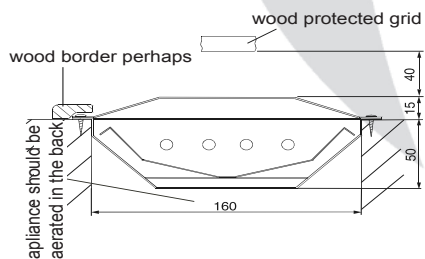

Vertical installation in the cabin corners

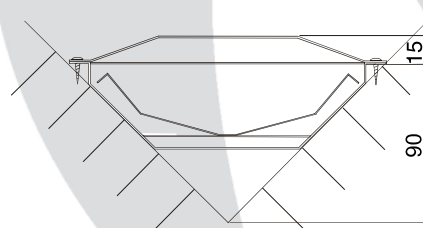

Front sight

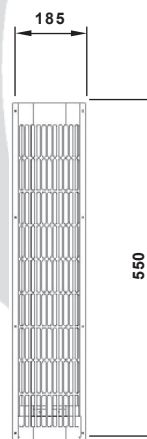

Cut-out of the wall

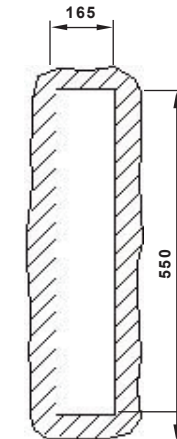

Art.No.	electrical connection / power	Emitter	Surface temperature	Spectrum	Dimensions H/W/D in cm	Cut-out for mounting	Weight without package	For operation with control units
94.1878	230 V N AC 50 Hz 300 W	Ceramics	400 - 600° C	2 - 10µm IR-B IR-C	55 / 18,5 / 6,5	55 x 16,5	ca. 2 kg	60 IR Infratec Classic Infratec Premium InfraTouch

29342545 31.12

